

English

Fitting Instructions:
Bonneville and Bonneville T100
A9528028

Thank you for choosing this Triumph genuine accessory kit. This accessory kit is the product of Triumph's use of proven engineering, exhaustive testing, and continuous striving for superior reliability, safety and performance.

Completely read all of these instructions before commencing the installation of the accessory kit in order to become thoroughly familiar with the kit's features and the installation process.

These instructions should be considered a permanent part of your accessory kit, and should remain with it even if your accessory-equipped motorcycle is subsequently sold.

A9528028

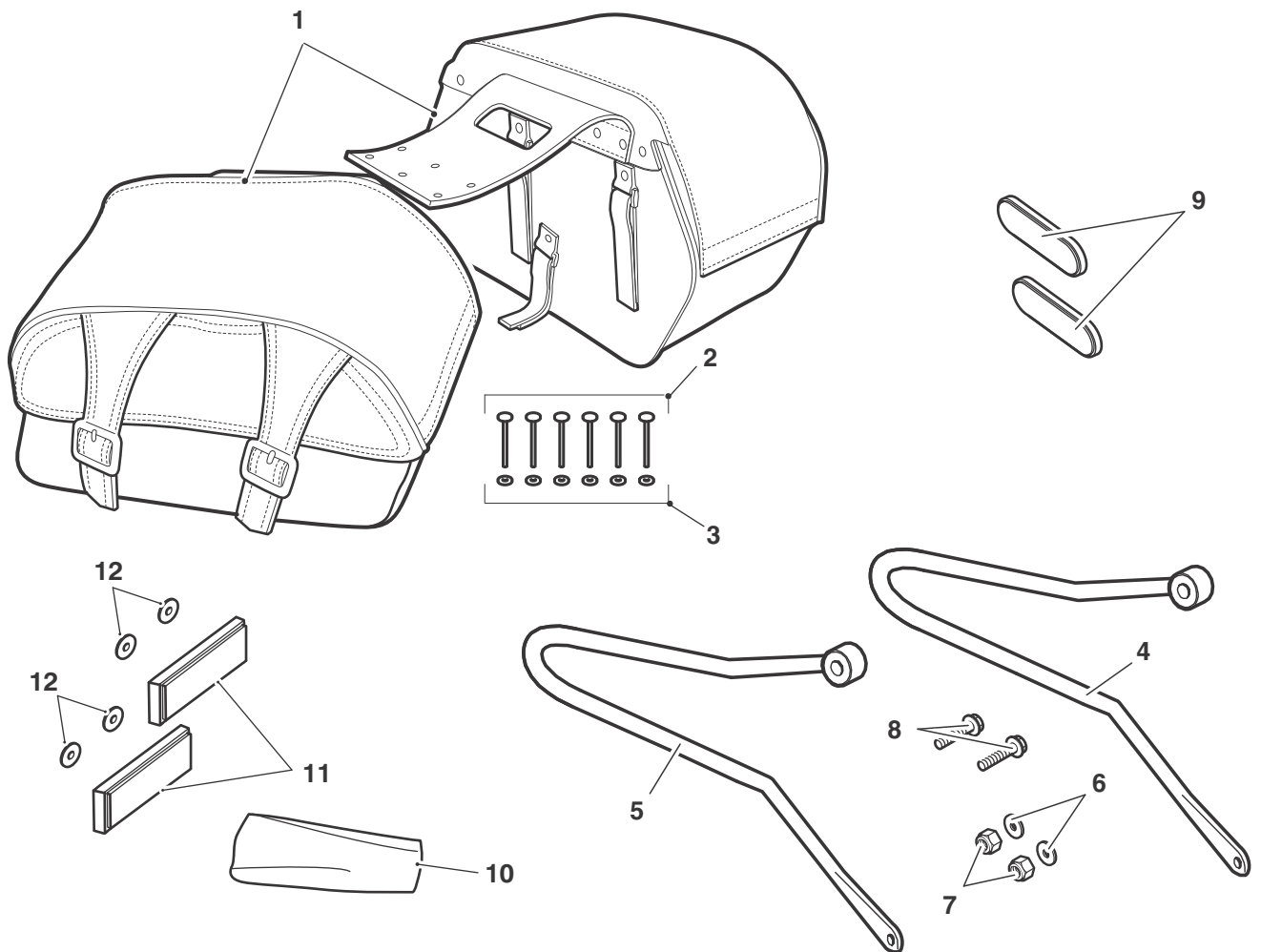

Parts Supplied:

1.	Saddlebag, classic, large, pair	1 off	7.	Lock nut, M8	2 off
2.	Rivet, plastic	6 off	8.	Screw, threadlock, M8 x 20 mm	2 off
3.	Clip, rivet, plastic	6 off	9.	Reflector, accessory kit with the self-adhesive reflector	2 off
4.	Pannier rail, left hand	1 off	10.	Cleaning wipe	1 off
5.	Pannier rail, right hand	1 off	11.	Reflector, accessory kit with the reflectors secured with retaining washers	2 off
6.	Washer, M8	2 off	12.	Retaining washers	4 off



Warning

This accessory kit is designed for use on Triumph Bonneville and Bonneville T100 motorcycles only and should not be fitted to any other Triumph model or to any other manufacturer's motorcycle. Fitting this accessory kit to any other Triumph model or to any other manufacturer's motorcycle will affect the performance, stability and handling of the motorcycle. This may affect the rider's ability to control the motorcycle and could cause an accident.



Warning

The saddlebags are designed solely for use in conjunction with the Triumph approved pannier rails provided in the kit. Do not attempt to mount the saddlebags onto the motorcycle without using the approved pannier rails. If the saddlebags are not correctly fitted, the handling and stability of the motorcycle will be adversely affected which may result in an accident causing injury or death.



Warning

Always have Triumph approved parts, accessories and conversions fitted by a trained technician of an authorised Triumph dealer. The fitment of parts, accessories and conversions by a technician who is not of an authorised Triumph dealer may affect the handling, stability or other aspects of the motorcycle's operation which may result in loss of motorcycle control and an accident.



Warning

Throughout this operation, ensure that the motorcycle is stabilised and adequately supported to prevent risk of injury from the motorcycle falling.



Warning

A torque wrench of known accurate calibration must be used when fitting this accessory kit. Failure to tighten any of the fasteners to the correct torque specification may result in loss of motorcycle control and an accident.



Warning

If the engine has recently been running, the exhaust system will be hot. Before working on or near the exhaust system, allow sufficient time for the system to cool, as touching any part of a hot exhaust could cause burn injuries.

Pannier Rail Fitment

1. Undo and remove the screws (and flanged sleeves if fitted) located at the rear of the seat.

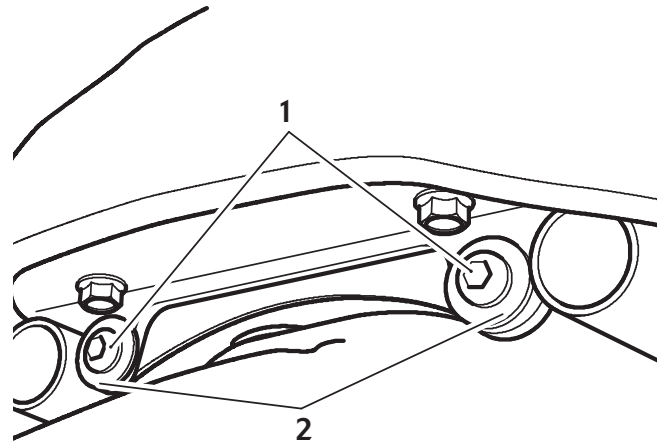

1. Screws
2. Flanged sleeves (if fitted)

2. Remove the seat.
3. Slacken and remove the left hand rear suspension unit upper mounting bolt and washer. Discard the bolt.

Note:

- **The bolt used to secure the upper suspension unit to its mounting point must not be re-used. Retain the washer for later use.**
4. Slacken and remove the nut securing the left hand passenger footrest to the frame.

Note:

- **Retain the nut for use if the motorcycle is returned to original condition.**

5. Fit the left hand pannier rail, engaging it with the suspension unit upper mounting point and passenger footrest bolt.

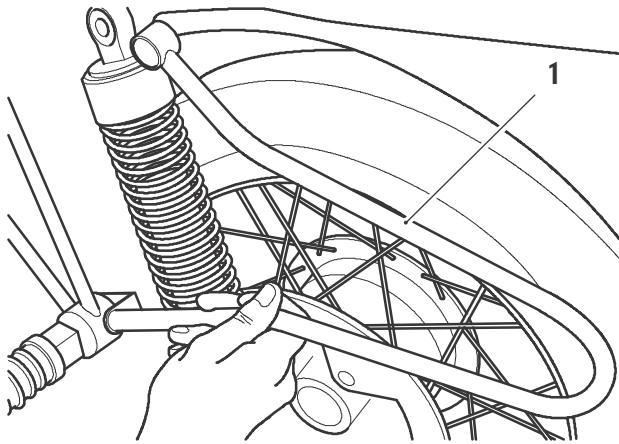

1. Pannier rail

6. Secure the rear suspension unit and pannier rail to the upper mounting point using the original washer and M8 x 20 mm threadlock screw supplied. Tighten the screw to **27 Nm**.
7. Fit an M8 lock nut and washer from the kit to the left hand passenger footrest and tighten to **27 Nm**.

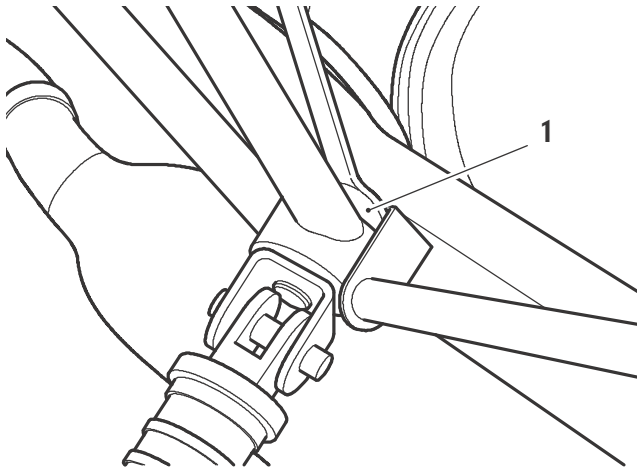

1. M8 lock nut and washer location

8. Repeat steps 3 to 7 for the right hand side.

Reflector Fitment - United States, Canada and Singapore Only

Note:

- If side reflectors are not required in your country or region, continue from step **22**.
- If fitting the self-adhesive reflectors, continue from step **9** and omit steps **13** to **21**.
- If fitting the reflectors secured by retaining washer omit steps **9** to **12** and continue from step **13**.

Notice

Failure to fit a reflector to each saddlebag as shown contravenes federal law and renders the motorcycle illegal for road use in the United States, Canada and Singapore. Always fit the reflectors as shown.

Accessory Kit with the Self-Adhesive Reflector

Caution

When fitting self-adhesive parts care must be taken to ensure positioning is correct and accurate. Once the adhesive has been attached to the mounting surface, there is no satisfactory method of removal and re-positioning if incorrectly aligned. Initial bonding is instant, full bonding is achieved after 72 hours.

Note:

- Read the warning notices printed on the cleaning wipe packet in the fitting kit.
- The surfaces to which the reflectors are affixed must be clean and dry to ensure that the adhesive has a sound base to adhere to. Use the cleaning wipe supplied for this purpose.

9. Clean the mounting surface area of the saddlebag with the cleaning wipe provided.

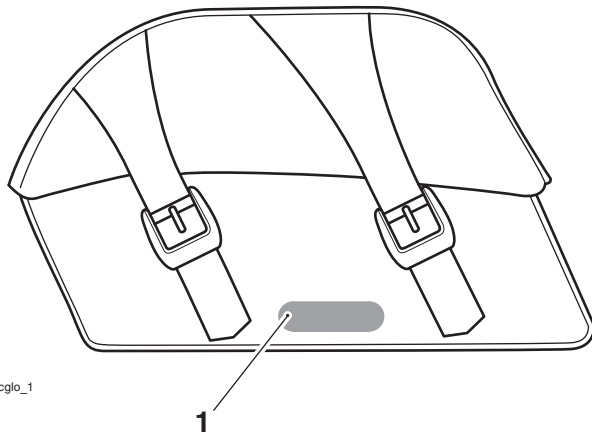

cglo_1

1. Cleaning area

10. Remove the protective film from the adhesive pad on the rear of the reflector.
11. Carefully locate the reflector on to the saddlebag centrally between the straps as shown below. Apply firm pressure to the entire reflector to ensure a good bond is achieved.

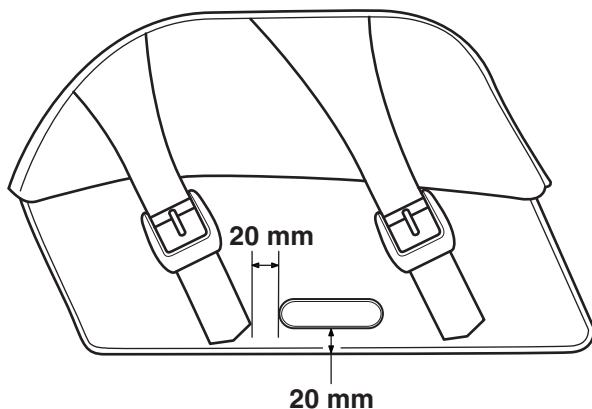

Location for Reflector

12. Repeat steps 9 to 11 for the other saddlebag.

Accessory Kit with the Reflectors Secured with Retaining Washers

13. Apply masking tape, larger than the size of the reflector, to the saddlebag as shown in the illustration below.

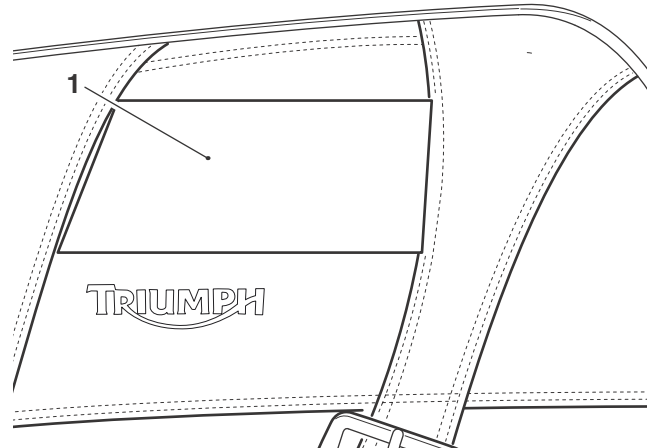

1. Masking tape, right hand saddlebag shown

14. From the top edge of the letters I and H of the word Triumph, measure 36 mm upwards. Mark the distance on to the masking tape.
15. Join the two marks on the masking tape with a straight line across the masking tape.

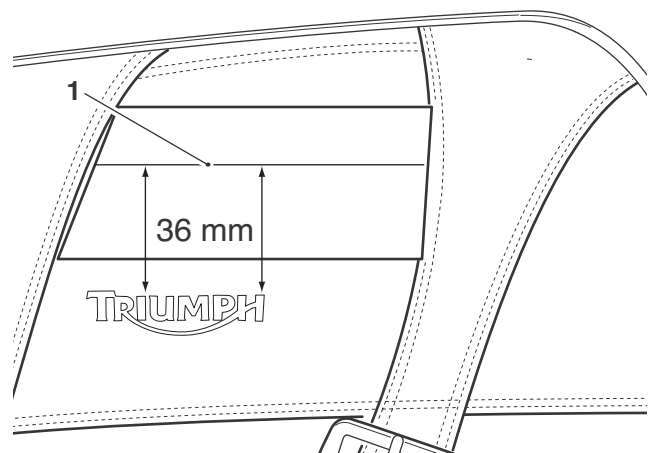

1. Drawn line

16. **Left hand saddlebag:** From the inner edge of the right hand strap, measure 47 mm along the drawn line and mark the line.
17. **Right hand saddlebag:** From the inner edge of the left hand strap, measure 47 mm along the drawn line and mark the line.

18. From the new mark, measure 50 mm and mark the line.

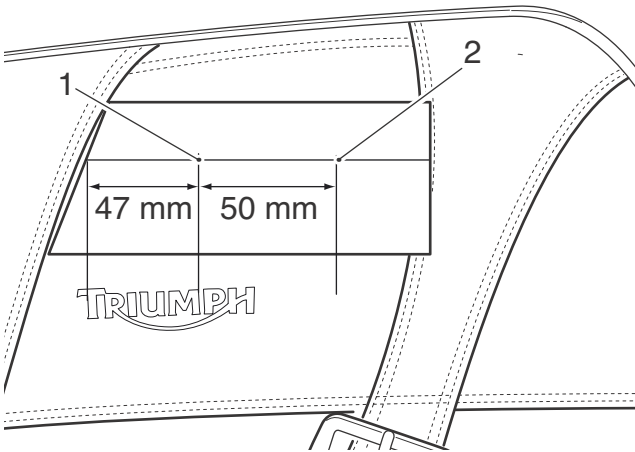

1. 47 mm distance, right hand saddlebag shown
2. 50 mm distance

Note:

- For both saddlebags, only drill through the saddlebag lid. Take care not to drill into any other part of the saddlebag.
19. Open the saddlebag lid of both saddlebags and drill a hole in each marked position using a 6 mm diameter drill.
20. Remove the masking tape and clean off any marks.
21. Fit the reflector to the saddlebag and secure in position with two retaining washers.

Saddlebag Fitment

22. Join the saddlebags as follows. Align the six holes in the joining strap of the right hand saddlebag with the outer six holes in the joining strap of the left hand saddlebag.

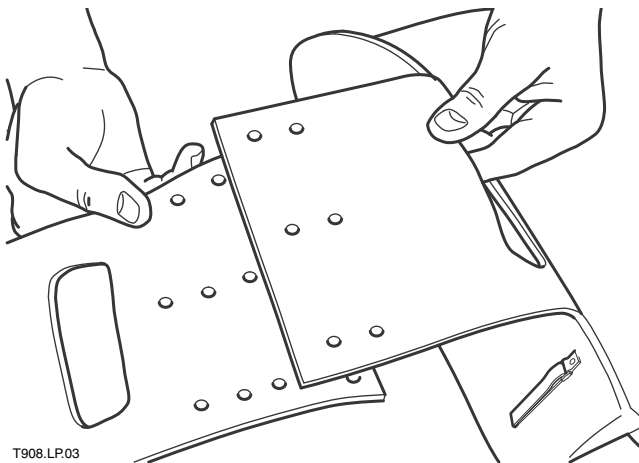

T908.LP.03

Hole Alignment

23. With the holes correctly aligned, insert the six plastic rivets through the holes from the underneath and slide a clip onto each rivet.

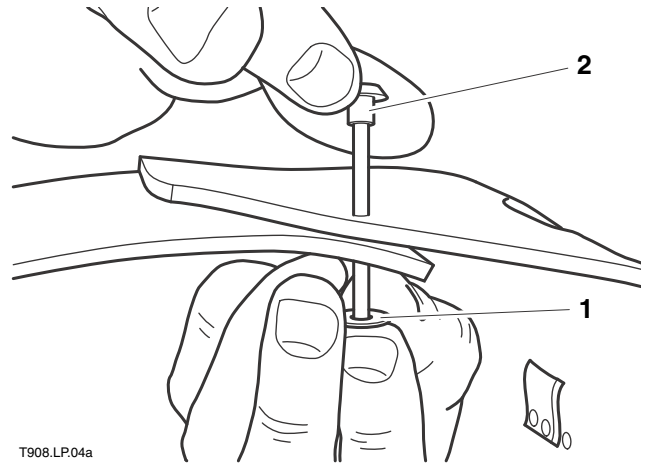

T908.LP.04a

1. Plastic rivet
2. Clip

24. Secure all six rivets using a pop rivet gun.

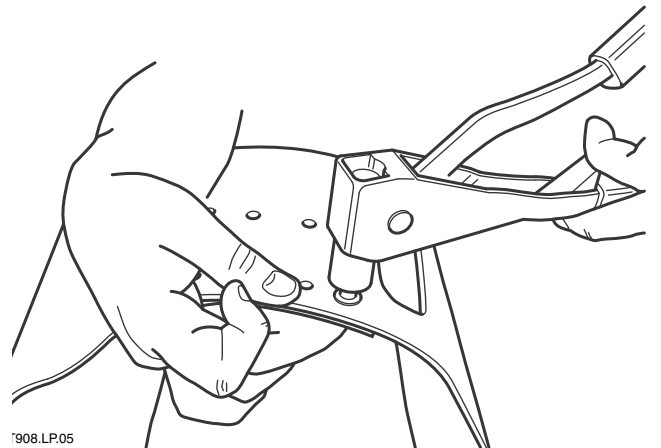

T908.LP.05

Rivet Fitment

25. Seat the saddlebags on the motorcycle.

Warning

When fitting the saddlebag straps to the pannier rails ensure the strap is fitted over the pannier rail before passing through the buckle. Failure to attach the saddlebags correctly to the pannier rails could result in the saddlebags becoming loose. This could affect the handling and stability of the motorcycle which may lead to loss of motorcycle control and an accident.

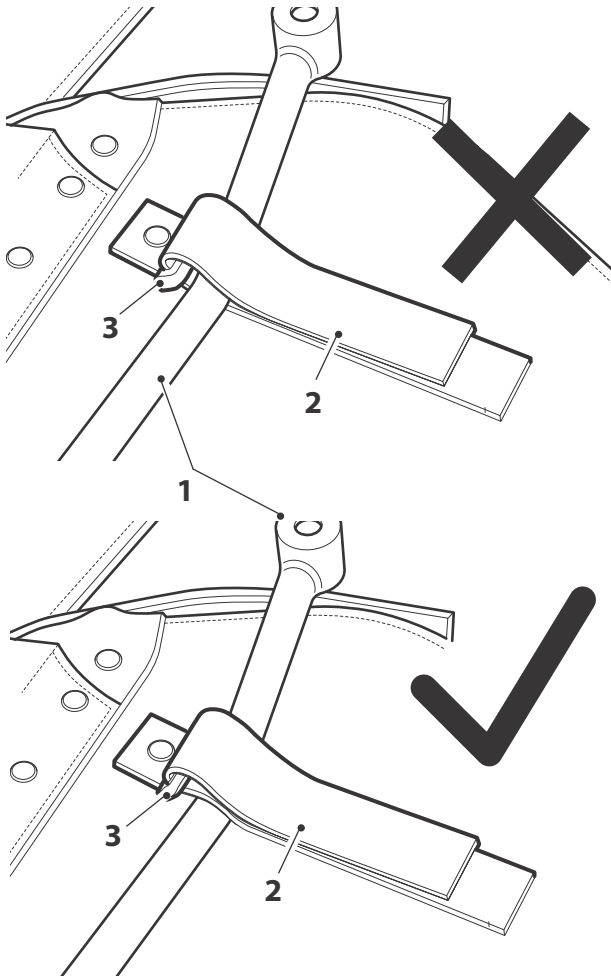

- 1. Pannier rail
- 2. Saddlebag strap
- 3. Buckle

- 26. Release the straps, fitted to the inner side surfaces of the saddlebags, from the hook and loop pads and pass the strap over the pannier rail and through the buckle as shown.

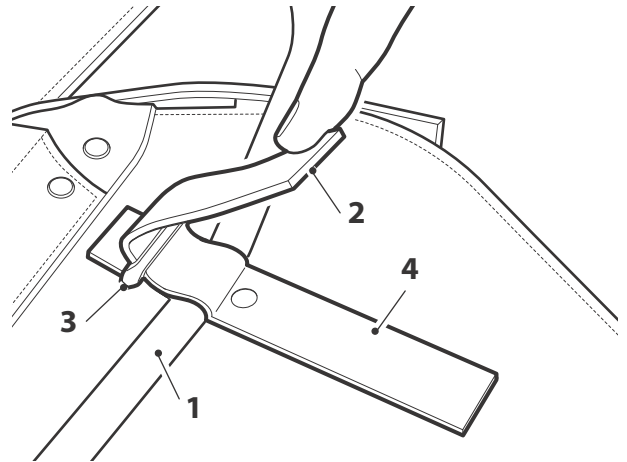

- 1. Pannier rail
- 2. Strap
- 3. Buckle
- 4. Hook and loop pad

- 27. Secure the ends of the straps to the hook and loop pads.
- 28. Check the security of the saddlebags.
- 29. Refit the seat, ensuring it is correctly located behind the fuel tank. Tighten the fixings to **8 Nm**.

Warning

If, after fitment of this accessory kit, you have any doubt about the performance of any aspect of the motorcycle, contact an authorised Triumph dealer and do not ride the motorcycle until the authorised dealer has declared it fit for use. Riding a motorcycle when there is any doubt as to any aspect of the performance of the motorcycle may result in loss of control of the motorcycle leading to an accident.

Warning

After fitting the saddlebag kit the motorcycle will exhibit new handling characteristics. Operate the motorcycle in a safe area free from traffic to gain familiarity with any new characteristics. Operation of the motorcycle when not familiar with any new handling characteristics may result in loss of motorcycle control and an accident.



Warning

The maximum safe load for each saddlebag is 3 kg (6.6 lbs). Never exceed this loading limit as this may cause the motorcycle to become unstable leading to loss of control and an accident.



Warning

In all cases, loads must be evenly distributed on both sides of the motorcycle. Uneven loading may cause instability, loss of control and an accident.



Warning

Never ride an accessory-equipped motorcycle at speeds above 80 mph (130 km/h).

The presence of accessories will cause changes in the stability and handling of the motorcycle. Failure to allow for changes in motorcycle stability may lead to loss of control or an accident.

Remember that the 80 mph (130 km/h) limit will be reduced by the fitting of non-approved accessories, incorrect loading, worn tyres, overall motorcycle condition and poor road or weather conditions.



Warning

The motorcycle must not be operated above the legal road speed limit except in closed course conditions.



Warning

Only operate this Triumph motorcycle at high speed in closed course, on-road competition or on closed course race tracks. High speed operation should only be attempted by riders who have been instructed in the techniques necessary for high speed riding and are familiar with the motorcycle's characteristics in all conditions. High speed operation in any other circumstances is dangerous and will lead to loss of motorcycle control and an accident.